



# 3.5" DPF Race Pipe

2018-2020 3.0 Powerstroke

 [support@minimaxxtuner.com](mailto:support@minimaxxtuner.com)

 [www.minimaxxtuner.com](http://www.minimaxxtuner.com)

 Minimaxxtuner

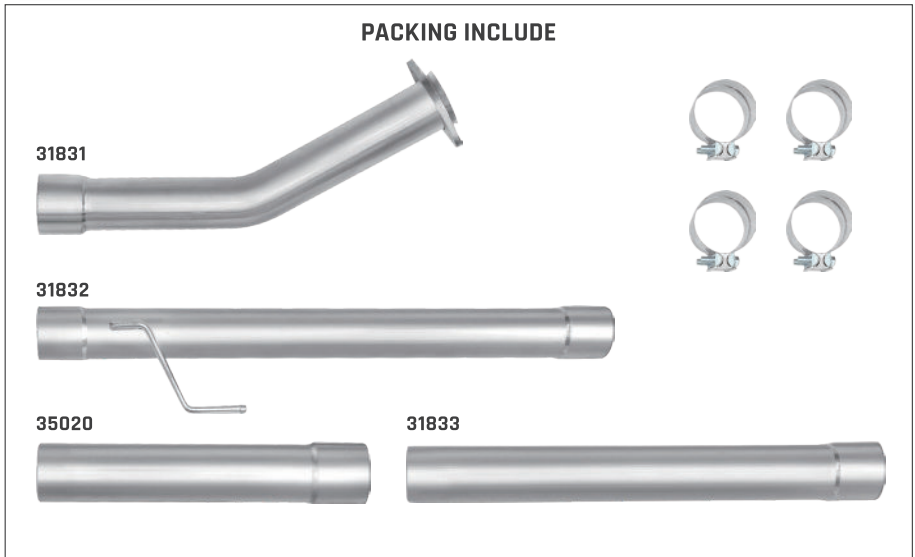

## WARNING

**Warning:** This system is designed for race use only. May also void manufacturer's warranty. Allow the truck's exhaust system to cool before removal. Always practice safe work habits, i.e. jack stands, gloves, safety glasses etc.

**Notes:** Performance Exhaust Systems are designed to fit stock trucks with OEM hitches, tires, wheels, and spare sizes. Any suspension lifts or other variations may require modification of the new exhaust system for proper fit and finish. WD40 or equal will make removal of hangers easier. A small tack with a mig welder is recommended on all clamp connections. DO NOT fully torque clamps until full system is installed and adjusted. Installation of this kit is intended to be done on a lift or hoist with at least two people.

## INSTALLATION NOTES

**Note:** Prior to installation, please compare the parts that you have received with the bill of materials listed above to ensure that you have all the necessary parts for installation.



## INSTALLATION STEPS

### Step 1:

Removal of OEM exhaust system, Remove the factory skid plate by loosening the 4 8mm bolts and 1 11mm nut.

### Step 2:

Remove all 9 sensors from DPF and SCR systems and tie them up out of the way.

### Step 3:

Loosen the bolt on the clamp holding the muffler and mid pipe together then remove the two hangers attached to the frame of the truck as show in figure A-1 and then remove the rearmost hanger that supports the tailpipe as shown in figure A-2.

FIG. A-1

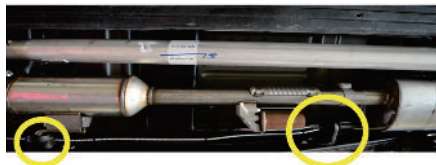
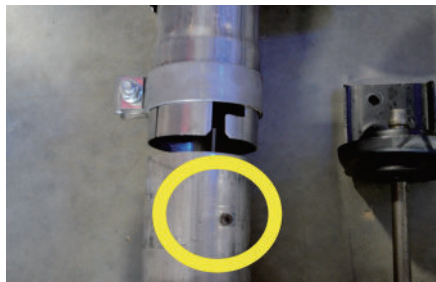

FIG. A-2



FIG. B-1



### Step 4:

Remove the 3 bolts in the flange in the middle of the factory system, now you are able to carefully twist the SCR pipe and the factory muffler/tailpipe assembly to release the slotted locator nub and pull the two pieces apart and remove the SCR pipe from the truck. See figure B-1.

### Step 5:

Install downpipe (part # 31831) and snug the nuts up so that the pipe can be moved with some effort.

FIG. C-1



### Step 6:

Install intermediate pipe (part #31832) sliding the hanger into the factory is o lat or as you connect to the downpipe. This connection should have 1.25" of overlap and your clamp should seat right on the edge of the expansion. See figure C-1.

### Step 7:

For Short box trucks, install the second mid pipe (part #31833) into the back of part #31832 and support with a stand. Note: Extension pipe #35020 may be required for longer box length and may require some trimming for a perfect fit.

### Step 8:

With the assistance of a friend, slide the factory muffler assembly back into the one hanger still attached to the frame and into the back of part #31833 at the same time.

### Step 9:

Reinstall the two hangers you previously removed. Check for overall alignment of the system and then starting at the turbo, tighten all bolts and clamped connection.

